

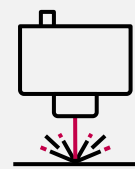

intelliWELD II FT

The clever all-rounder

- Dynamic focal spot adjustment
- Ideal for on-the-fly welding of lap joints
- Better overview through real-time status monitoring



**3D scan system
laser welding**

Smart welding with the intelliWELD II FT

The intelliWELD 3D scan systems have been developed for a wide range of different welding applications. They are able to cover a three-dimensional space in which parts can be processed.

The scanner is designed for on-the-fly operation, in which a handling device moves the scan system in a simply programmed path over the component and the welding task is carried out simultaneously to the movement.

The intelliWELD II FT deflects the laser beam quickly, precisely and with high repeatability. The fast movements of the deflection mirrors increase the process speed and reduce the positioning time from weld seam to weld seam (jump time) to a few milliseconds. The optional superimposition of a welding figure with oscillation geometries enables the welding result to be optimized even with complex tasks.

The intelliWELD II FT offers the possibility of realizing variable spot diameters and thus flexible seam widths, making it particularly suitable for overlap welding. The optional zoom function allows the user to vary the spot size during the welding process. The optics are optimized for fiber-coupled disk or fiber lasers with power outputs of up to 8 kW. The Blackbird software monitors and displays all key scan system status parameters in real time.

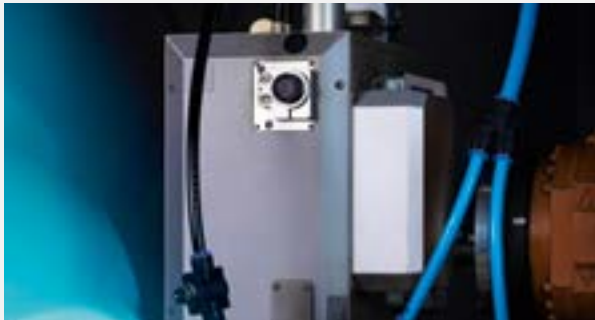

Dynamic focal spot adjustment

- The seam width can be adjusted flexibly within a seam or with different weld seams on one or different components.
- High-frequency oscillations of up to 1000 Hz can also be placed over the seam geometry.

Ideal for on-the-fly welding of lap joints

- Small optical magnification (small spots) can also be achieved with low beam quality or large fiber diameters.
- The spot size can be adjusted depending on the properties of each material.

Better overview through real-time status monitoring

- Monitoring of the most important measured values by intelligent sensors in real time
- Early warning in the event of increased stress or incorrect settings
- Integral safety concept with numerous options for laser and process control

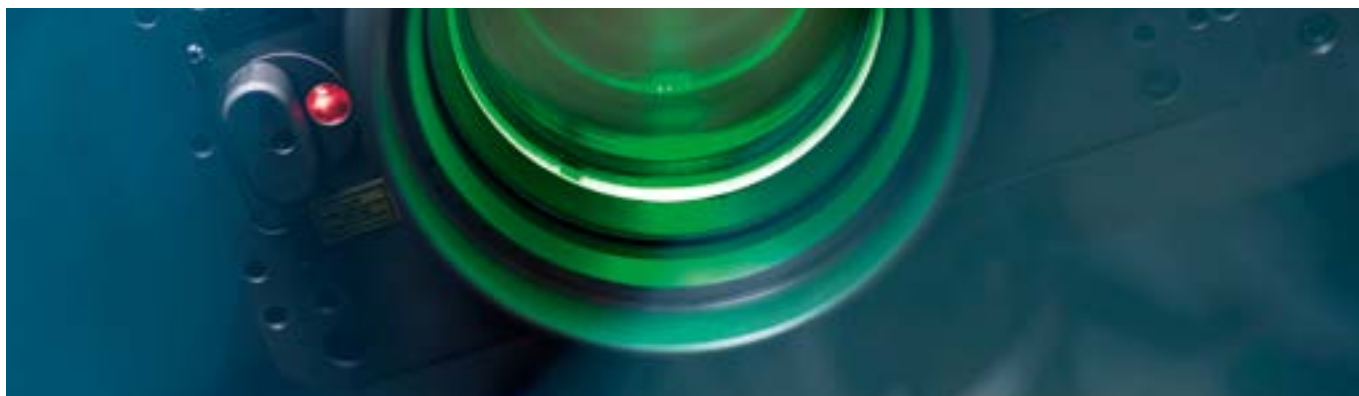

Optical specifications intelliWELD II FT

Focal length collimator in mm	125		142	
Focal length focussing optics in mm	255	460	255	460
Fiber adapter	QBH / QD (LLK-D)			
Wavelength	1030 - 1085 nm + NIR			
Limiting NA (half angle) @ 86 % in rad	0.087	0.087	0.073	0.073
Limiting NA (half angle) @ 98.x % in rad	0.130	0.130	0.110	0.110
Optical magnification	1 : 2.0	1 : 3.7	1 : 1.8	1 : 3.2
Image field size @ z = 0 (elliptical) in mm	160 × 90	370 × 250	160 × 90	370 × 250
Image field size @ z = 0 (rectangular) in mm	100 × 80	220 × 220	100 × 80	220 × 220
Focus stroke in z-direction - / + in mm	25	70	25	70
Maximum laser power in kW	8			
Fiber diameter in µm	≥ 50			
Working distance (lower edge scanner) in mm	371	541	371	541

Options and extensions



Extensive Blackbird sensors

With the ScaVis camera system, the component position can be recorded in static applications and used to correct the seam position. The Blackbird OCT system complements the system with seam tracking and inspection for on-the-fly applications.

Zoom axis

With an additional zoom axis, the focus diameter can be increased continuously and highly dynamically by a factor of 1.5. The existing intensity distribution (e.g. top hat profile) is retained and any defocusing along the seam remains unaffected.

On-the-fly welding

On-the-fly (OTF) welding allows the scanner or the component to be moved during the welding process. This reduces the processing time to the shortest possible and increases the efficiency of the system. The Blackbird controller can perform OTF welding in conjunction with robots (e.g. KUKA, ABB or Yaskawa) or with one or two linear axes.



Air management

With the proven interaction of a Crossjet, process nozzles, fume protection module and supplied purge air, the deposition of smoke and particles on optical components is prevented and the service life of your scan system is maximized.

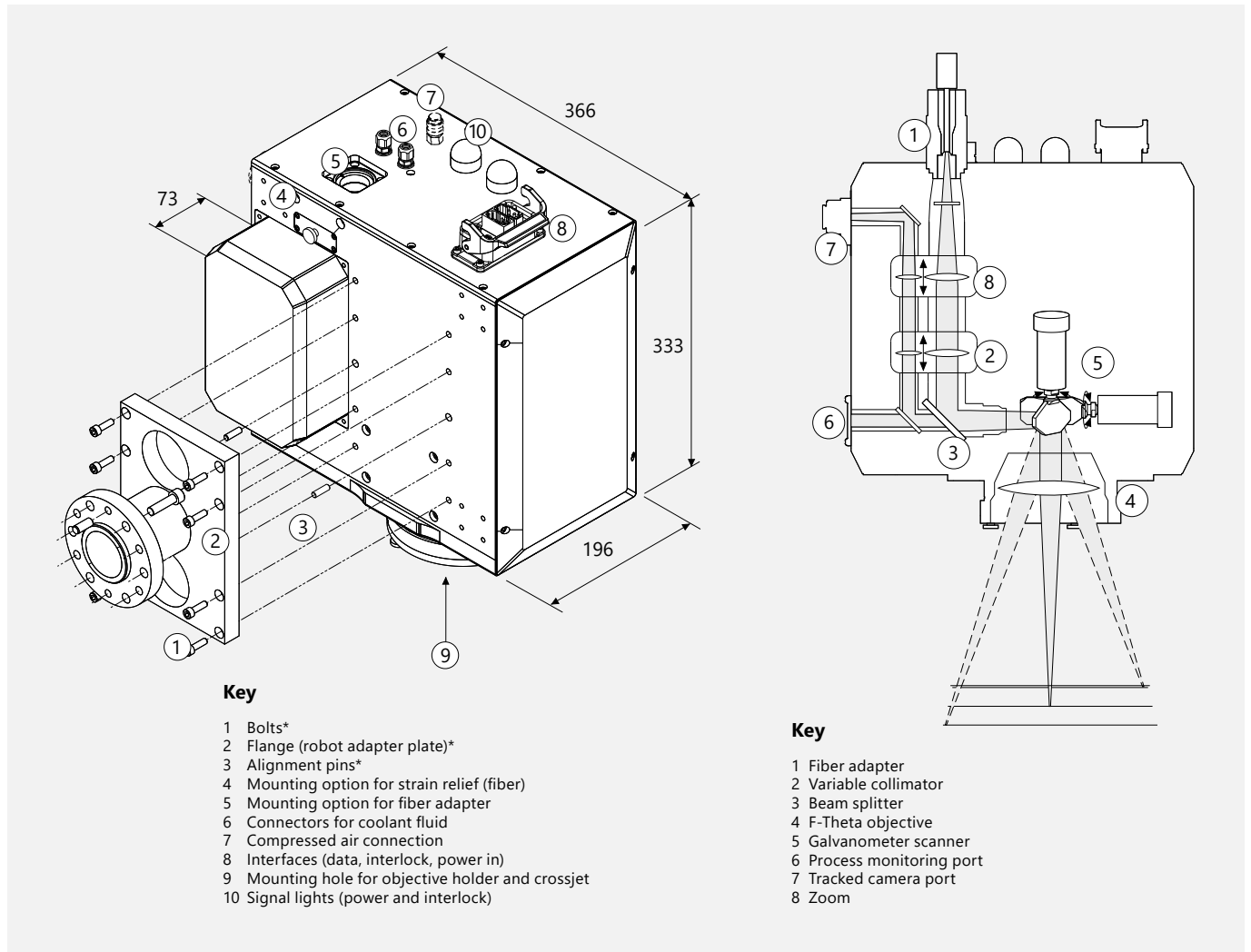

Key

- 1 Bolts*
- 2 Flange (robot adapter plate)*
- 3 Alignment pins*
- 4 Mounting option for strain relief (fiber)
- 5 Mounting option for fiber adapter
- 6 Connectors for coolant fluid
- 7 Compressed air connection
- 8 Interfaces (data, interlock, power in)
- 9 Mounting hole for objective holder and crossjet
- 10 Signal lights (power and interlock)

Key

- 1 Fiber adapter
- 2 Variable collimator
- 3 Beam splitter
- 4 F-Theta objective
- 5 Galvanometer scanner
- 6 Process monitoring port
- 7 Tracked camera port
- 8 Zoom

All dimensions in mm

*Not included in the delivery

Technical data

Weight (with / without attachments)	30.5 kg (w/o zoom), 35.5 kg (w/ zoom)
Operating temperature	25 °C ± 10 °C
Supply voltage (supplied by the Blackbird control system)	30 V DC (29 – 33 V), respective max. 8 A
Water cooling specification	2 l/min at 20 °C and Δp < 0.1 bar; p < 4 bar
Filter unit purge air specification	ISO 8573 - 1 : 2010, class 5.4.4
Supplementary set for cooling water connection	Optional
Repeatability (RMS)	< 2 μrad
Long term drift over 8 h (at operating temperature)	< 0.15 mrad
Tracked camera port observation channel 2 (top)	C-Mount (optional)
Double cover slide (beam exit)	Yes
Purge Air between inner & outer cover slide	Yes
Cover slide sensor (beam exit)	Yes
Cover slide collimator	Yes, interchangeable
Flow sensor (cooling water)	Yes
Teach support	Yes
IP protection class	IP54

